

Microcontroller

MICRO 8051

8051

Contents:

- ◆ *Introduction*
- ◆ *8051 Architecture*
- ◆ *Addressing Modes*
- ◆ *Timers*



Introduction

- *An example for CISC Processor.*
- *Harvard Architecture*
- *Collection of 8 and 16 bit registers and 8 bit memory locations.*
- *External Memory can be interfaced.*

Pin Description of the 8051

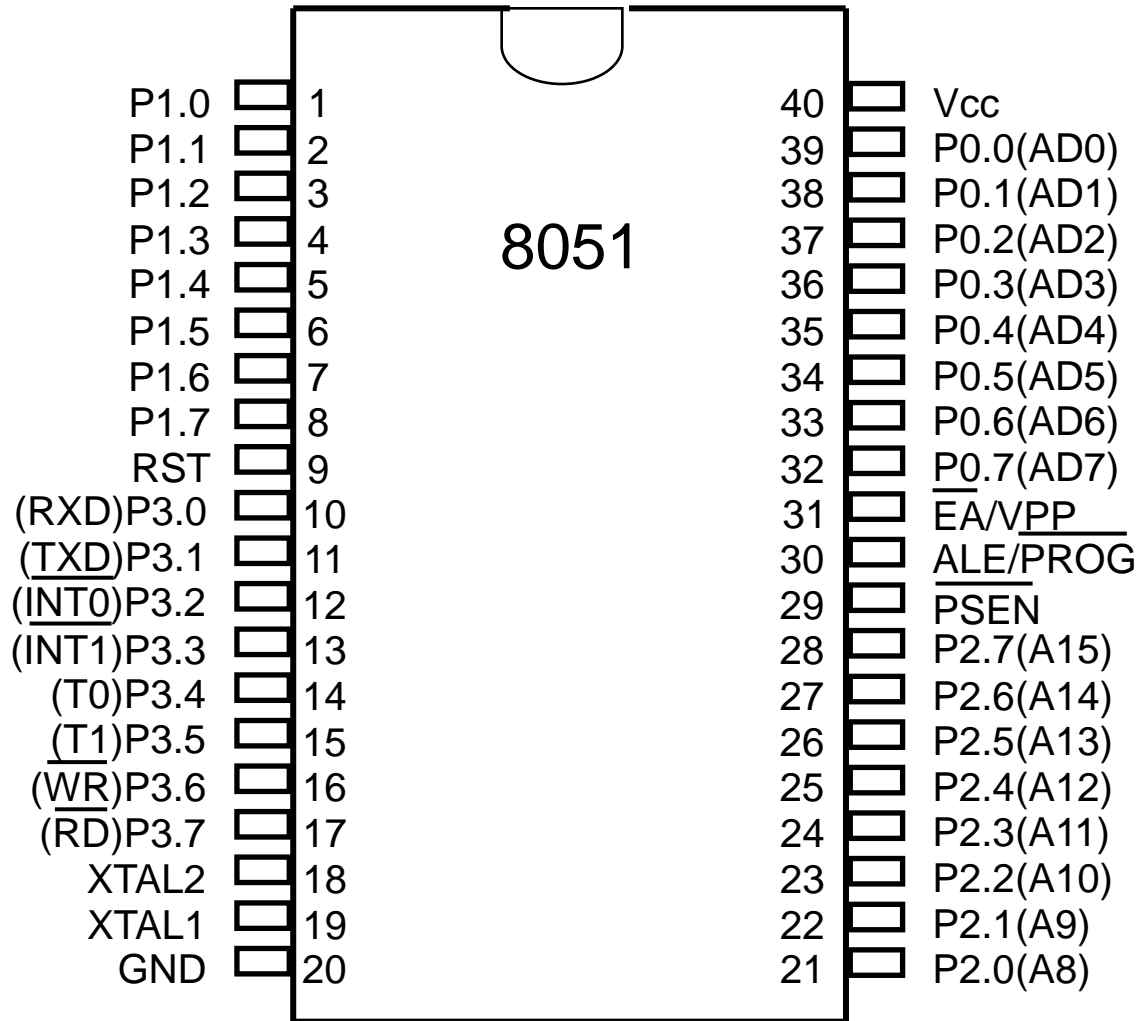

Pins of 8051 (1/4)

- Vcc (pin 40) :
 - Vcc provides supply voltage to the chip.
 - The voltage source is +5V.
- GND (pin 20) : ground
- XTAL1 and XTAL2 (pins 19,18) :
 - These 2 pins provide external clock.

Pins of 8051 (2/4)

- RST (pin 9) : reset
 - It is an input pin and is active high (normally low) .
 - Upon applying a high pulse to RST, the microcontroller will reset and all values in registers will be lost.

Pins of 8051 (3/4)

- /EA (pin 31) : external access
 - The /EA pin is connected to GND to indicate the code is stored externally.
 - For 8051, /EA pin is connected to Vcc.
 - “/” means active low.
- /PSEN (pin 29) : program store enable
 - This is an output pin and is connected to the OE pin of the ROM

Pins of 8051 (4/4)

- ALE (pin 30) : address latch enable
 - It is an output pin and is active high.
 - 8051 port 0 provides both address and data.
 - The ALE pin is used for de-multiplexing the address and data by connecting to the G pin of the 74LS373 latch.
- I/O port pins
 - The four ports P0, P1, P2, and P3.
 - Each port uses 8 pins.
 - All I/O pins are bi-directional.

Figure 3.1a 8051 Block Diagram

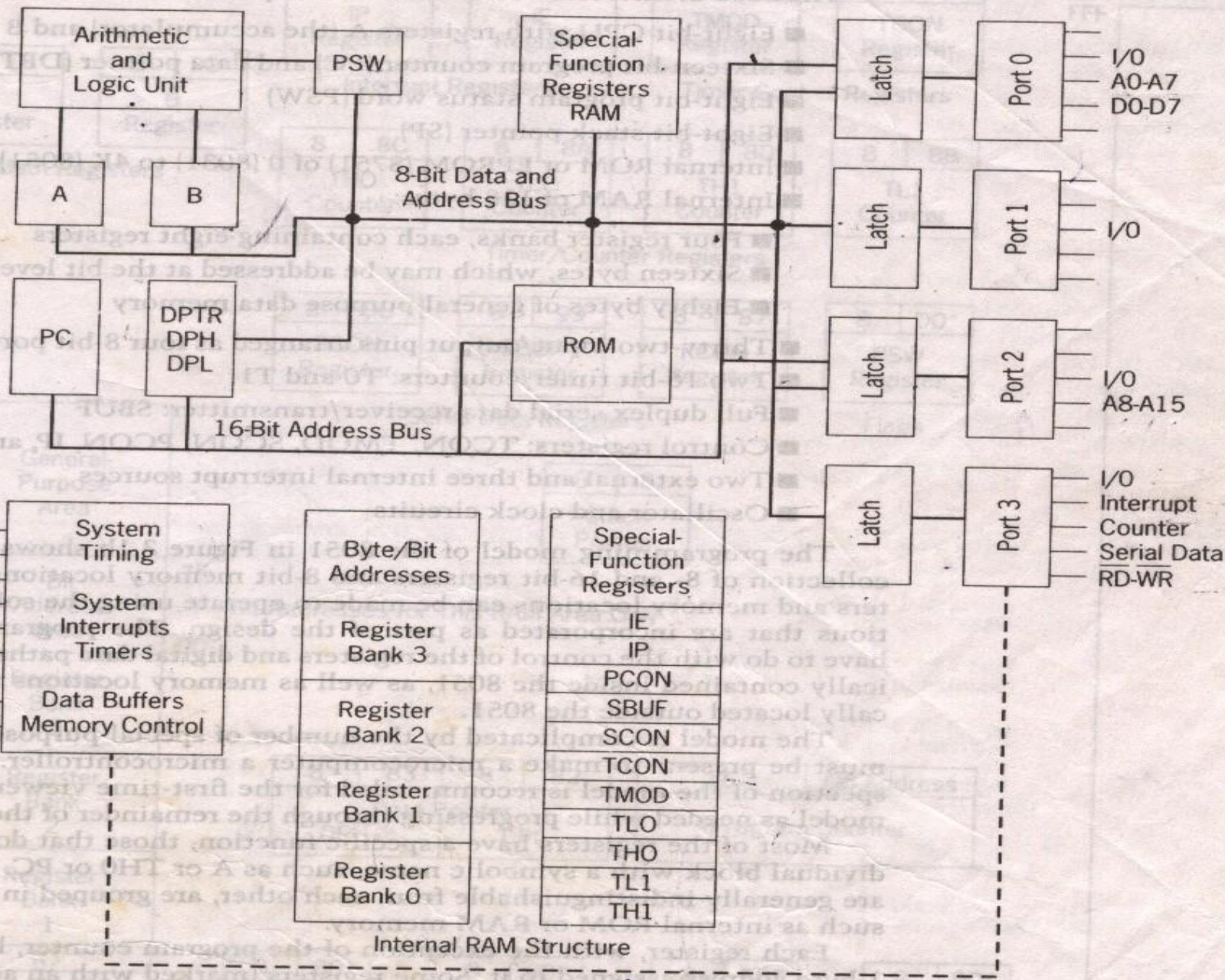

- *Internal ROM and RAM*
- *I/O Ports with programmable Pins*
- *ALU*
- *Working Registers*
- *Clock Circuits*
- *Timers and Counters*
- *Serial Data Communication.*

Figure 3.1b 8051 Programming Model

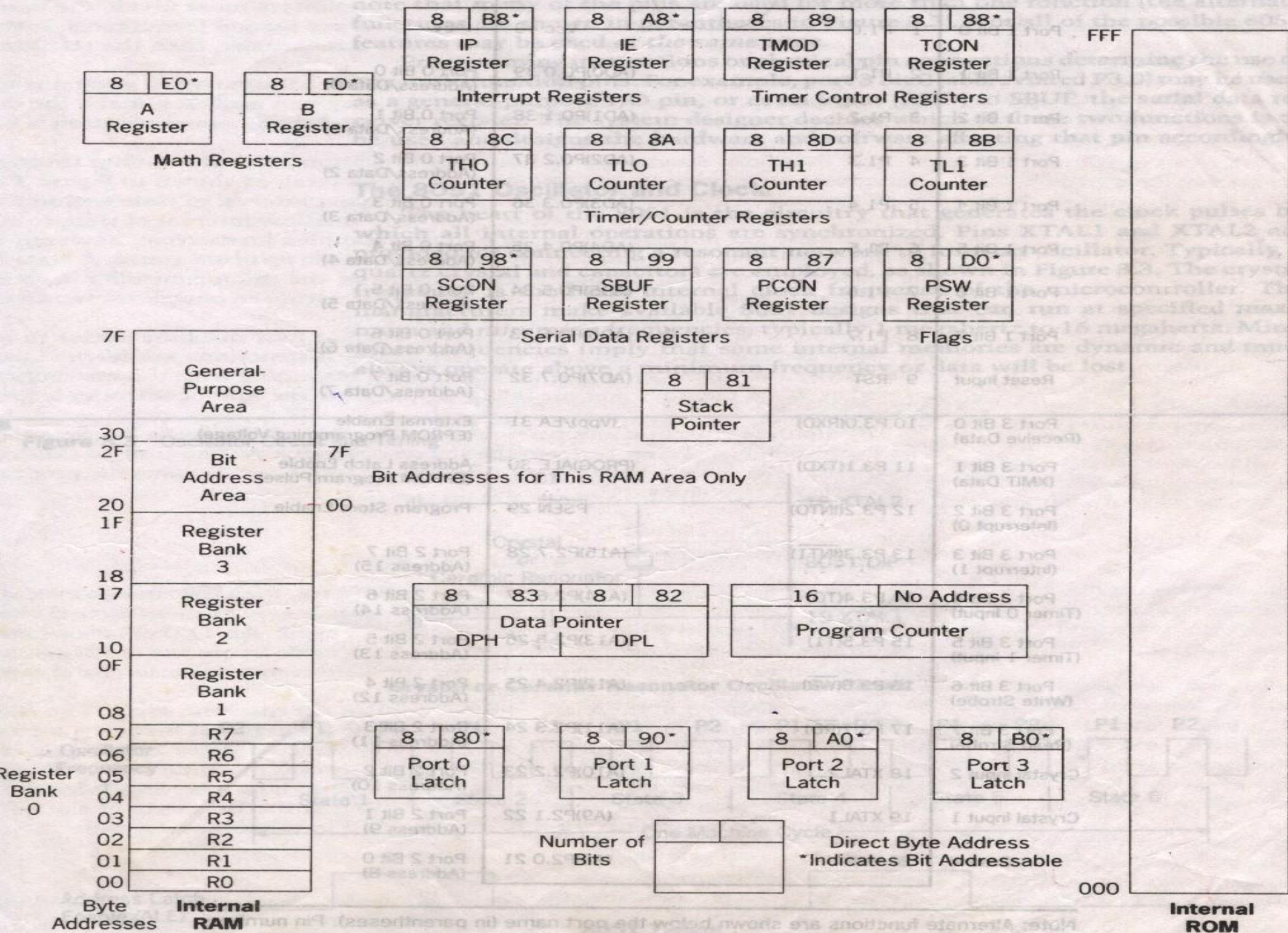

Specific Features

- 8 bit cpu with registers A and B
- 16 bit PC and DPTR(data pointer).
- 8 bit program status word(PSW)
- 8 bit Stack Pointer
- 4K Internal ROM
- 128bytes Internal RAM
 - →4 register banks each having 8 registers
 - 16 bytes,which may be addressed at the bit level.
 - 80 bytes of general purpose data memory

Specific Features

- 32 i/o pins arranged as 4 8 bit ports:P0 to P3
- Two 16 bit timer/counters:T0 and T1
- Full duplex serial data receiver/transmitter
- Control registers:TCON,TMOD,SCON,PCON,IP and IE
- Two external and Three internal interrupt sources.
- Oscillator and Clock Circuits.

Pins of I/O Port

- The 8051 has four I/O ports
 - Port 0 (pins 32-39) : P0 (P0.0~P0.7)
 - Port 1 (pins 1-8) : P1 (P1.0~P1.7)
 - Port 2 (pins 21-28) : P2 (P2.0~P2.7)
 - Port 3 (pins 10-17) : P3 (P3.0~P3.7)
 - Each port has **8 pins**.
 - Named P0.X (X=0,1,...,7) , P1.X, P2.X, P3.X
 - Ex : P0.0 is the bit 0 (LSB) of P0
 - Ex : P0.7 is the bit 7 (MSB) of P0
 - These 8 bits form a byte.
- Each port can be used as input or output (bi-direction).



Program Counter & Data Pointer

- *They are both 16 bit registers.*
- *Each is to hold the address of a byte in memory*
- *PC contains the address of the next instruction to be executed.*
- *DPTR is made up of two 8 bit register DPH and DPL;*
- *DPTR contains the address of internal & external code and data that has to be accessed.*

A and B CPU registers

- Totally 34 general purpose registers or working registers.
- Two of these A and B hold results of many instructions, particularly math and logical operations of 8051 cpu.
- The other 32 are in four banks, B0 – B3 of eight registers each.
- A(accumulator) is used for addition, subtraction, mul, div, boolean bit manipulation and for data transfers.
- But B register can only be used for mul and div operations.

8051 Flag bits and the PSW register

- PSW Register

CY	AC	F0	RS1	RS0	OV	--	P
----	----	----	-----	-----	----	----	---

<i>Carry flag</i>	PSW.7	CY
<i>Auxiliary carry flag</i>	PSW.6	AC
<i>Available to the user for general purpose</i>	PSW.5	--
<i>Register Bank selector bit 1</i>	PSW.4	RS1
<i>Register Bank selector bit 0</i>	PSW.3	RS0
<i>Overflow flag</i>	PSW.2	OV
<i>User define bit</i>	PSW.1	--
<i>Parity flag Set/Reset odd/even parity</i>	PSW.0	P

RS1	RS0	Register Bank	Address
0	0	0	00H-07H
0	1	1	08H-0FH
1	0	2	10H-17H
1	1	3	18H-1FH

- *Two flag bits are stored in PCON(Power control) registers also.*
- *They are the GF1 (3RD) and GF0(2nd) bits*
- *They are general purpose user flag bit 1 and 0 respectively*
- *They can be set or cleared by the program*
- *For more details of PCON, refer fig 3.13 in text book.*

Memory Organization

- RAM memory space allocation in the 8051

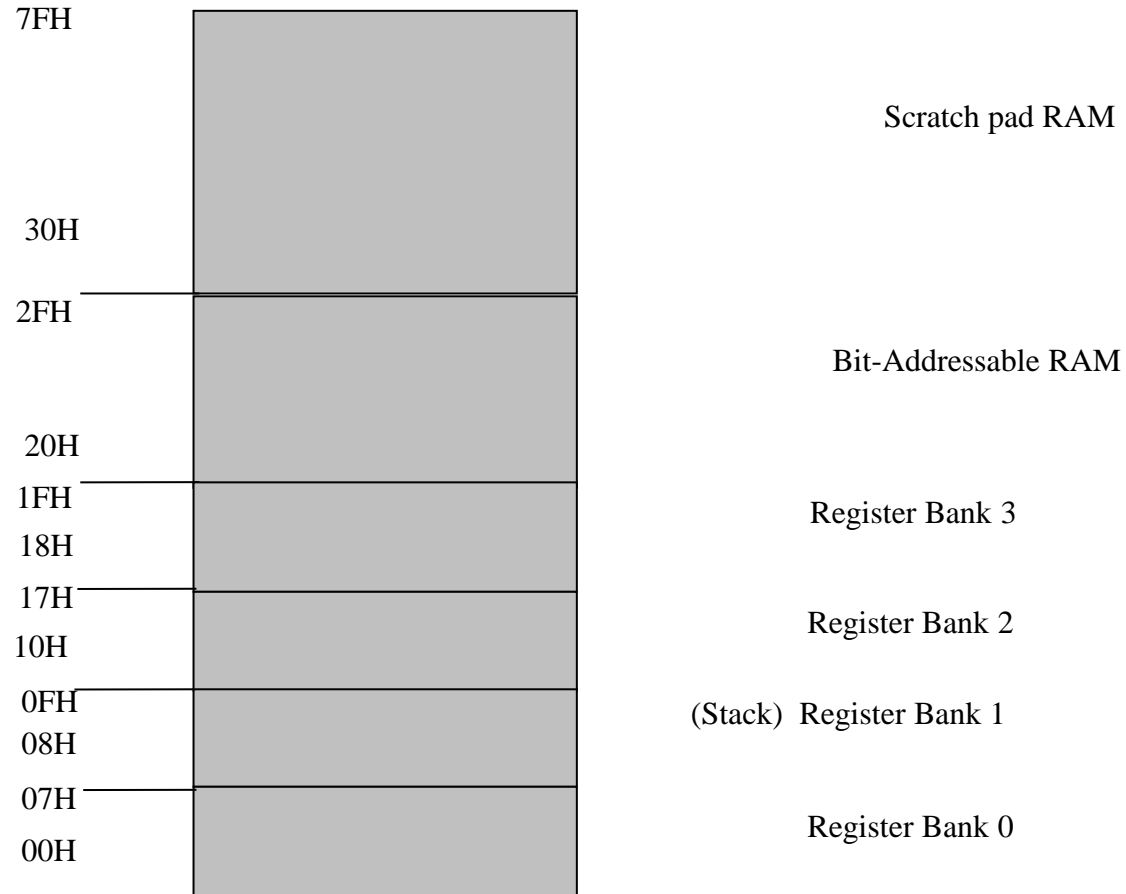

Stack in the 8051

- The register used to access the stack is called **SP** (stack pointer) register.
- The stack pointer in the 8051 is only 8 bits wide, which means that it can take value 00 to FFH. When 8051 powered up, the SP register contains value 07.

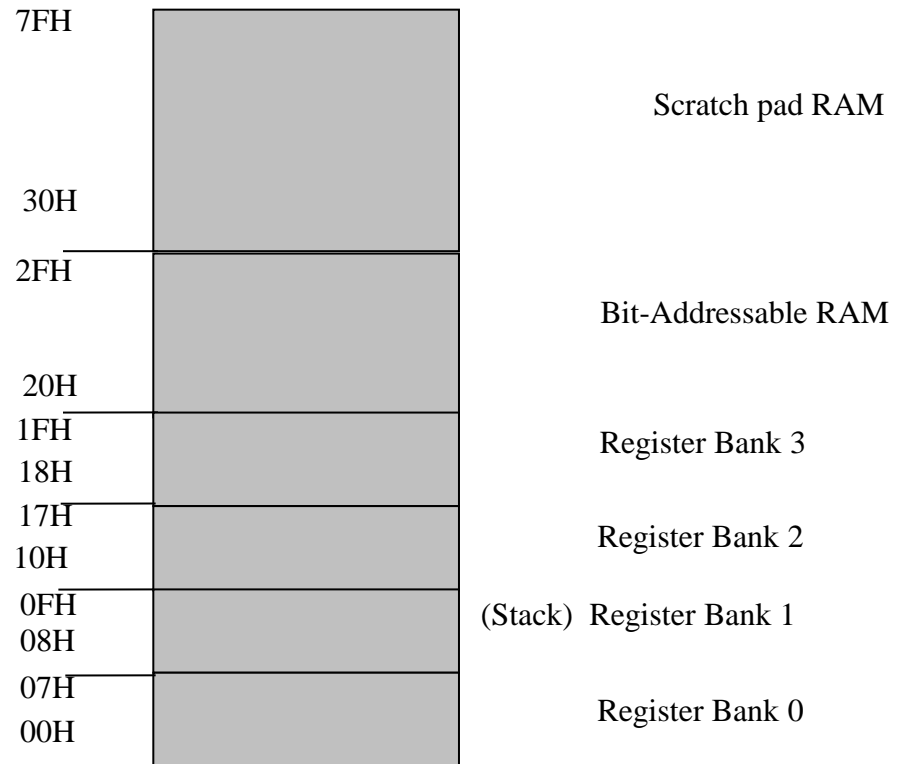

Special Function Registers

Name	Function	Name	Function
A	Accumulator	SBUF	Serial Port data buffer
B	Arithmetic	SP	Stack Pointer
DPH	Addressing Ext Memory	TMOD	Timer/Counter mode cntrl
DPL	Addressing Ext Memory	TCON	Timer/Counter cntrl
IE	Interrupt enable	TL0	Timer0 lower byte
IP	Interrupt Priority	TH0	Timer0 higher byte
P0	I/O Port Latch	TL1	Timer1 lower byte
P1	I/O Port Latch	TH1	Timer1 higher byte
P2	I/O Port Latch		
P3	I/O Port Latch		
PCON	Power Control		
PSW	Pgm Status Word		
SCON	Serial PortCntrl		

I/O Port Programming

Port 0 (pins 32-39)

- *When connecting an 8051 to an external memory, the 8051 uses ports to send addresses and read instructions.*
- *16-bit address : P0 provides both address A0-A7, P2 provides address A8-A15.*
- *Also, P0 provides data lines D0-D7.*
- *When P0 is used for address/data multiplexing, it is connected to the 74LS373 to latch the address.*

Port 1 (pins 1-8)



- Port 1 is denoted by P1.
 - P1.0 ~ P1.7
 - P1 as an output port (i.e., write CPU data to the external pin)
 - P1 as an input port (i.e., read pin data into CPU bus)

ALE Pin

- The ALE pin is used for de-multiplexing the address and data by connecting to the G pin of the 74LS373 latch.
 - When $ALE=0$, P0 provides data D0-D7.
 - When $ALE=1$, P0 provides address A0-A7.
 - The reason is to allow P0 to multiplex address and data.

Port 3 (pins 10-17)

- Although port 3 is configured as an output port upon reset, this is not the way it is most commonly used.
- Port 3 has the additional function of providing signals.
 - Serial communications signal : RxD, TxD
 - External interrupt : /INT0, /INT1
 - Timer/counter : T0, T1
 - External memory accesses : /WR, /RD

Port 3 Alternate Functions

P3 Bit	Function	Pin
P3.0	RxD	10
P3.1	TxD	11
P3.2	$\overline{\text{INT0}}$	12
P3.3	$\overline{\text{INT1}}$	13
P3.4	T0	14
P3.5	T1	15
P3.6	$\overline{\text{WR}}$	16
P3.7	$\overline{\text{RD}}$	17



Addressing Modes

The way in which the instruction is specified.

- Immediate
- Register
- Direct
- Register Indirect
- Indexed

Immediate Addressing Mode

- Immediate Data is specified in the instruction itself

- Egs:

MOV A,#65H

MOV A,#'A'

MOV R6,#65H

MOV DPTR,#2343H

MOV P1,#65H

Register Addressing Mode

MOV Rn, A ;n=0,...,7

ADD A, Rn

MOV DPL, R6

~~MOV DPTR, A~~

~~MOV Rm, Rn~~

Direct Addressing Mode

Although the entire of 128 bytes of RAM can be accessed using direct addressing mode, it is most often used to access RAM loc. 30 – 7FH.

MOV R0, 40H

MOV 56H, A

MOV A, 4 ; \equiv MOV A, R4

MOV 6, 2 ; copy R2 to R6

; **MOV R6,R2 is invalid !**

Register Indirect Addressing Mode

- In this mode, register is used as a pointer to the data.

MOV A,@Ri

; move content of RAM loc. Where address is held by Ri into A
(i=0 or 1)

MOV @R1,B

In other word, the content of register R0 or R1 is sources or target in MOV, ADD and SUBB insructions.

☒ [_jump](#)

Indexed Addressing Mode And On-Chip ROM Access

- This mode is widely used in accessing data elements of look-up table entries located in the program (code) space ROM at the 8051

MOVC A, @A+DPTR

A = content of address A + DPTR from ROM

Note:

Because the data elements are stored in the program (code) space ROM of the 8051, it uses the instruction MOVC instead of MOV. The “C” means code.